

4B Bases and Accessories

Overview

Detector bases provide the physical mounting for their detectors, and the electrical connections to their detectors.

This leaflet is intended for use in planning and implementing an installation. It provides specifications and useful notes on the 4B series bases.

The 4B series derives its name from widest the diameter of the bases, which is 4" (approximately 100 mm).

Figure 1 shows a typical base in the series (the 4B-C). The numbered items are explained further throughout this guide.

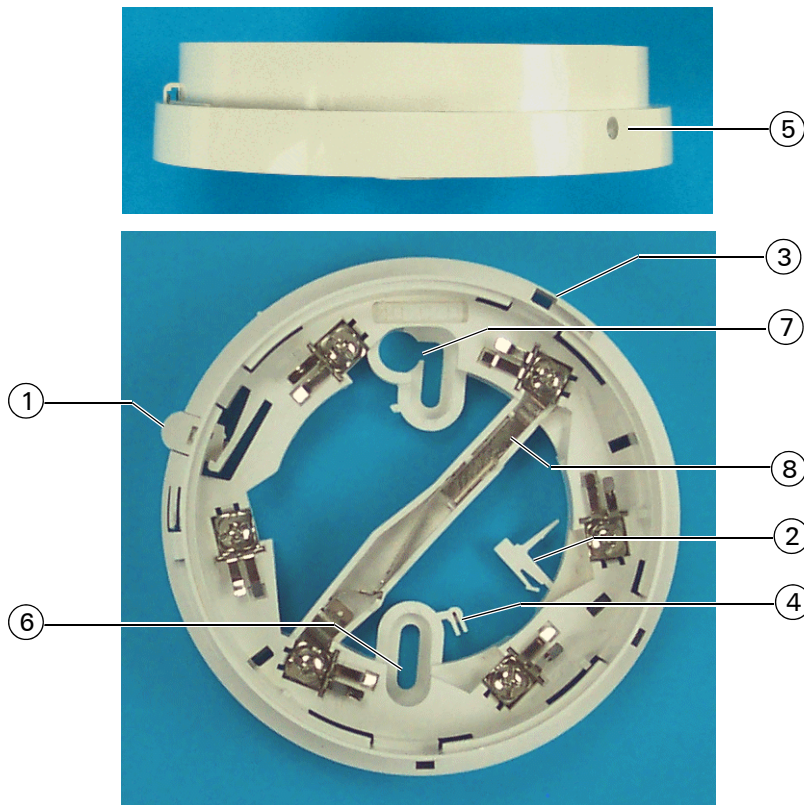

Fig. 1: 4B-C 4" base

- 1-Temporary park plunger
- 2-Detector locking pin (as supplied)
- 3-Detector locking pin fits here
- 4-LED aperture plug (as supplied)
- 5-LED aperture plug fits here
- 6-Fixing screw slot
- 7-Fixing screw slot enlarged
- 8-Continuity Spring loaded contact (4B-C only)

Variants

There are a number of variants in the series, to suit varying installation requirements and detector design. All the vari-

ants are similar, in terms of construction and dimensions. The variants are summarised in Table 1.

Name	Summary	Usage	Typical Wiring Details
4B	Base variant.	Use with 830 series detectors.	Figure 5 on page 4
4B-C	Continuity base. For use with detectors that normally provide the continuity of the loop. On removing the detector a spring loaded contact closes to maintain loop continuity. The contact is item 8 in Figure 1.	Use with 850 series detectors.	Figure 7 on page 5
4B-I	Isolator base. If a loop short circuit is detected on one side of the base, loop continuity is automatically broken to maintain a functioning section of loop on the other side of the base. The base itself remains functioning. Once the short circuit is no longer detected, loop contiguity is automatically restored.	Use with 830 series detectors.	Figure 6 on page 4

Table 1: 4B Base Variants

Inserting Detectors

To fit a detector to a base

- 1 Identify the raised rib alignment markers on the edges of the detector and base.
- 2 With the detector marker positioned approximately 15 mm/15 ° anti-clockwise from the base marker, offer up and mate the detector to the base.
- 3 Twist the detector clockwise to align the markers and lock the detector in place.

Detector locking

Normally the detector is removed by first rotating it anti-clockwise to disengage the contacts.

This rotation can be prevented, using the detector locking pin.

To use the locking pin

- 1 Snap the pin free of the moulding (see Item 2 in Figure 1).
- 2 Insert the pin into its aperture on the rim of the base (see Item 3 in Figure 3). The pin should sit flush in its aperture, with the sprung tab upwards.
- 3 Fit a the detector to the base as normal.

Now, before the detector can be removed, you need to depress the sprung tab of the locking pin. To do this use a

suitable tool inserted into the access hole in the detector cover. As an example of a suitable tool, see the section "Lock release tool".

Lock release tool

For details on using a lock release tool see the section "Detector locking".

For the lock release tool, a small diameter flat ended rod is all the is required. This could be made by adapting a screwdriver as shown in Figure 2.

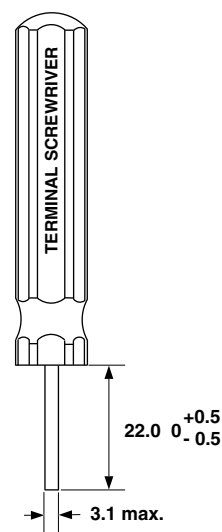

Fig. 2: Making an unlocking tool
1-End ground down perpendicular to shaft

Park Position

The Park position allows you to fit a detector into a base to keep them together. However electrical contact is not made, so the detector is not installed into the system.

The sections below cover using the Park position. You can also use the Park position with the Detector Removal Tool (see "Detector Removal Tool" on page 10).

To fit a detector to a base in the Park position

- 1 Off up and mate the detector, as described in the section "Inserting Detectors", steps 1 and 2.
- 2 Depress and hold in the Temporary Park Plunger (see item 1 in Figure 1).
- 3 Twist the detector anti-clockwise until you feel resistance (approximately 10 mm/10 °).
- 4 Release the plunger.

To take a detector out of Park position

- 1 Depress and hold in the Temporary Park Plunger.
- 2 Twist the detector clockwise approximately 10 mm/10 °.
- 3 Release the plunger.
- 4 Remove the detector.

Labelling

For labelling the base is fitted with an Address Flag. This can then be fitted with Address Flag Labels.

There are two options for labelling:

- Pre-printed Address Flag Labels, fitted to address flags.
- Dymo-tape labels, fitted to 4B-DAF DIN Address Flags.

An Address Flag is shown in Figure 3, the 4B-DAF DIN Address Flag is very similar.

The Address Flag is first fitted to the detector. On fitting the detector to the base, the flag is then transferred to the base.

If the detector is removed the Address Flag remains with the base.

The address label carrier is made from Flame Retardant PC-ABS.

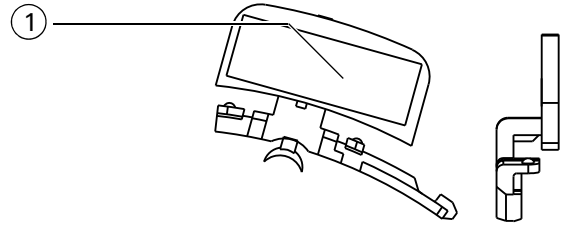

Fig. 3: Address Label Flag
1 – Address label flag affixed here

The Dymo labels should be to the following format:

- Tape width: 12mm
- Tape length: 52 mm maximum
- Font size: 10mm
- Layout: zzzzz / nn or zzzzz - nn

Where zzzzz is the zone number and nn is the detector address within this zone.

LED aperture plug

Bases with an isolating function have an indicator LED fitted. This leaves an empty aperture in bases without an isolator. You can optionally plug this aperture.

The LED aperture plug is shown in Figure 4.

Following is a procedure for inserting the plug. Using a screwdriver makes the procedure less difficult.

To insert the LED plug

- 1 Snap the plug free of the moulding (see Item 4 in Figure 1).
- 2 Insert a small flat bladed screwdriver into the plug slot.
- 3 From the inside, push the plug into the aperture, as shown in Figure 4.



Fig. 4: Inserting the LED aperture plug

Technical specification

Physical

- Dimensions
 - Height: 25 mm
 - Diameter overall: 109 mm
- Material
 - Base: Flame Retardant PC-ABS
 - Base Contacts: annealed spring steel
 - Base screws: stainless steel
- Weight
 - Base: 0.064 kg

Environmental

- Operating Temperature: -25 °C to +70 °C (+90 °C for short periods)
- Storage Temperature: -40 °C to +80 °C
- Relative Humidity: 95 % non-condensing

Wiring

The base wiring differs according to particular base and detector variants.

Some simplified typical wiring diagrams are shown in the figures below.

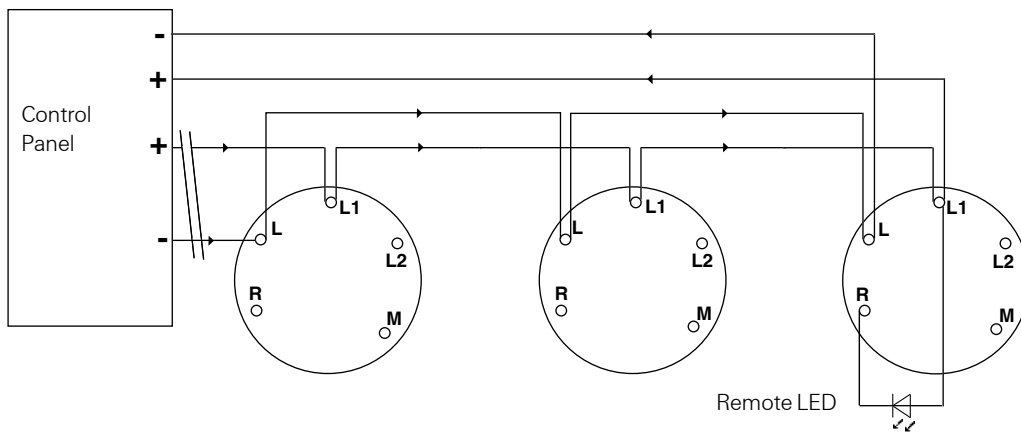

Fig. 5: Typical implementation wiring diagram – 4B

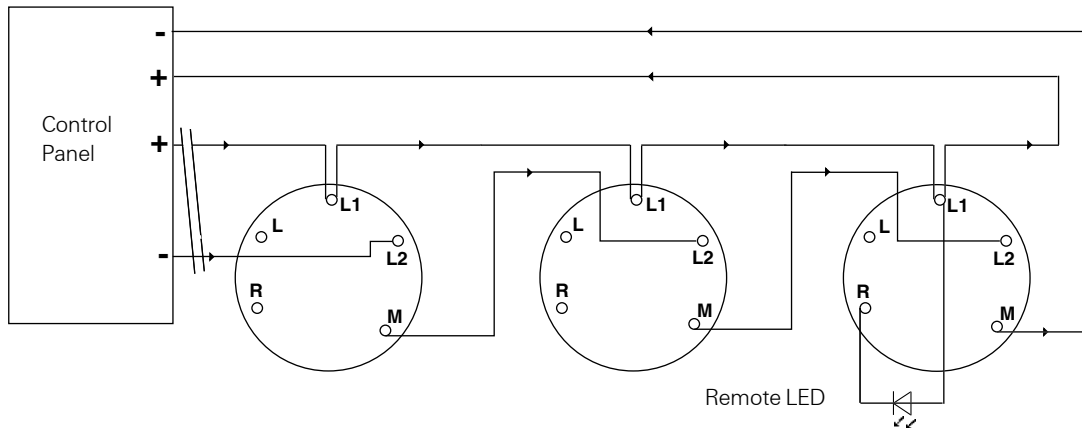

Fig. 6: Typical implementation wiring diagram – 4B-Isolator Base

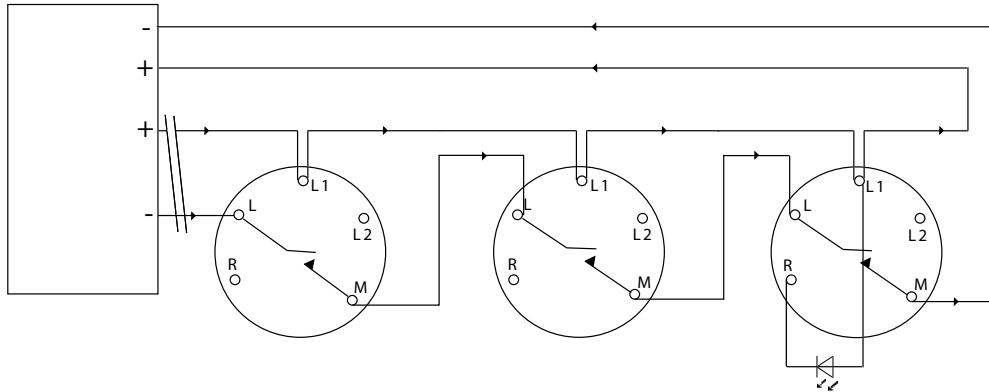

Fig. 7: Typical implementation wiring diagram – 4B-C Continuity Bases

Fixing

As described in the sections below, a 4B base can be fixed to the following:

- Conduit junction boxes.
- 4B-DHM Deckhead mountings.
- 4B-EM Euro Mounting Boxes.
- CTA-BB/CTA-BC Ceiling Tile Adapters.
- Directly to the ceiling.

A 4B base cannot be used with:

- EM-5B Euro Mounting Box
- DHM-5B Deckhead Mounting

Fixing Screw Slots

The fixing screw slots are shown as item 6 and 7 in Figure 1.

Direct fixing to surfaces

The base can be fixed directly to surfaces such as plywood ceilings. The surface should be flat in the area covered by the base, to ensure stability.

Use two No. 8 x 1.5" pan head screws, or the equivalent.

Conduit junction box

The base can be fitted to conduction junction boxes, at fixing centres of either 50 mm (British standard) or 70 mm (European standard).



Fig. 8: Conduit Junction Box
1 – Fixing centre

4B-DHM deckhead mounting

The Deckhead Mounting is designed to be used in particularly damp or dirty environments. The kit is illustrated in Figure 9.

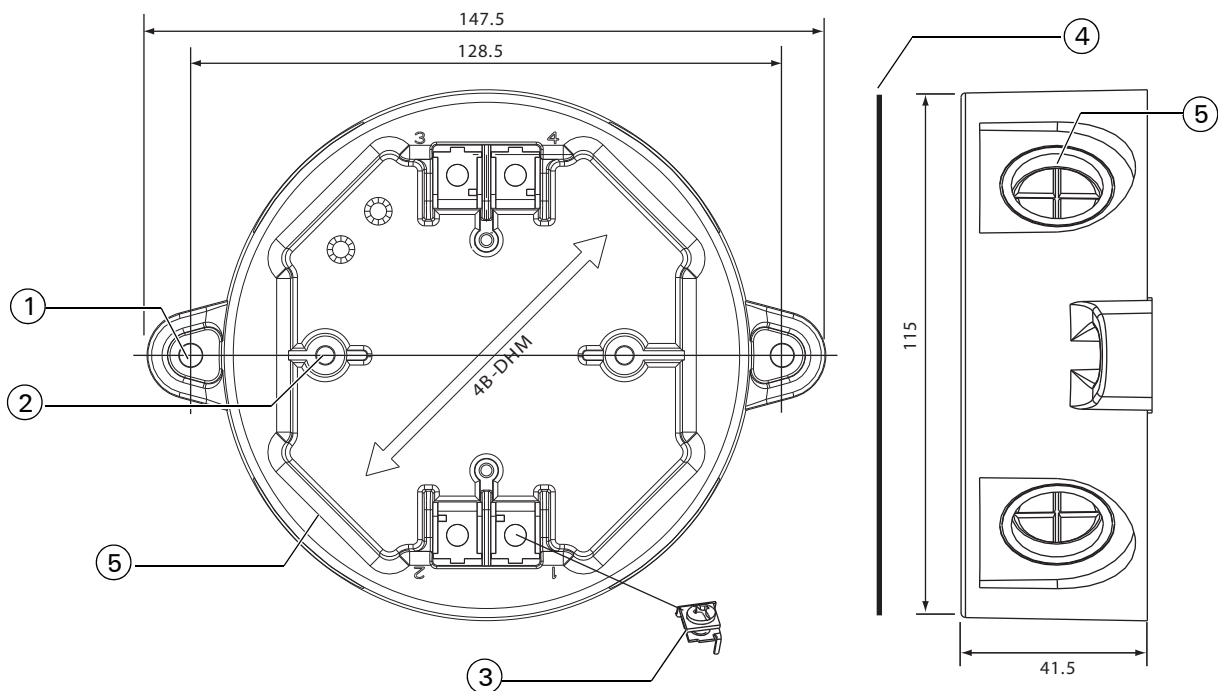

Fig. 9: 4B-DHM deckhead mounting
 1–Fixing hole (x 2). 5 mm diameter
 2–Detector base mounting post (x 2)
 3–Base accessory terminal (only one factory fitted – more can be ordered)
 4–Sealing gasket
 5–Gland/conduit knockout, 4 positions. 20 or 25 mm diameter

The Deckhead Mounting Kit comprises:

- The mounting housing.
- Two self tapping posidrive pan head screws to secure the detector base.
- Sealing gasket.

4B-DHM Technical specification

- Weight: 200 g
- Material
 - Body: glass filled P.B.T.
 - Base Accessory Terminal: annealed spring steel
 - Base Accessory Terminal Screw: stainless steel
- Environmental
 - Storage Temperature: -30 °C to +75 °C
 - Operating Temperature: -25 °C to +70 °C
 - Relative Humidity: up to 95 % RH (non-condensing)

To install the 4B-DHM

- 1 Note that the item numbers in this procedure refer to Figure 9. Remove gland/conduit knockouts (Item 5) as appropriate. For the larger 25 mm diameter, a hole cutter is required.
- 2 Note the alignment required for detector Status Indicator LED visibility.
An arrow is embossed in the bottom of the 4B-DHM. Mount the 4B-DHM so this arrow is aligned in the direction required for visual inspection of the detector Status Indicator LED.
- 3 Choose a mounting position that that is flat in the area contacting the housing.
To mount using welding, now jump to the section “4B-DHM Installation – welded” on page 7. Otherwise carry on at the next step.
- 4 Fix the 4B-DHM to the surface by screwing through the fixing holes – item 1 in Figure 9.
For the screws, use two No. 8 x 1” countersunk zinc plated and passivated steel screws, for example.
- 5 Remove the backing from the sealing gasket (Item 4 in Figure 9). Carefully stick the gasket to the front surface of the 4B-DHM. Fit the gasket round the rim, so that it will form a seal with the detector base.
- 6 Fit the LED Aperture Plug to the base – see the section “LED aperture plug” on page 3.
- 7 Secure the base to the 4B-DHM using the supplied two 4.2 x 25mm self tapping posidrive pan head screws.

4B-DHM Installation – welded

You will have jumped here from Step 3 in the procedure “To install the 4B-DHM” on page 6.

The 4B-DHM can be fixed to metal surfaces using welding. Two screws are inserted into the back of the 4B-DHM. These screws are then welded to the surface.

To fix the 4B-DHM using welding

- 1 Position the 4B-DHM so the flat base (that contacts the mounting surface) is towards you. This position corresponds to Figure 10. The item numbers in Figure 10 are referred to in this procedure.
- 2 Using pliers, nibble away the thin knockout section in the circular wall (Item 4).

- 3 Cover the knockouts and surrounding area with high temperature masking tape. This provides protection from weld spatter. Clear the tape from over the knockouts with a knife.
- 4 Insert screws (not supplied) into the holes (Item 1) . Use 6.3 x 25mm (No. 14 x 1") self tapping screws.
- 5 Using a double sided adhesive pad (Item 2), or tape, fix the 4B-DHM to the surface.
- 6 Weld the screw heads to the surface. Use Mig/ Tig welding for approximately 1.5 seconds per weld. For access, use the knockouts you removed previously.
- 7 Remove the masking tape and clean away any deposits.
- 8 Jump back to Step 5 in the procedure “To install the 4B-DHM”.

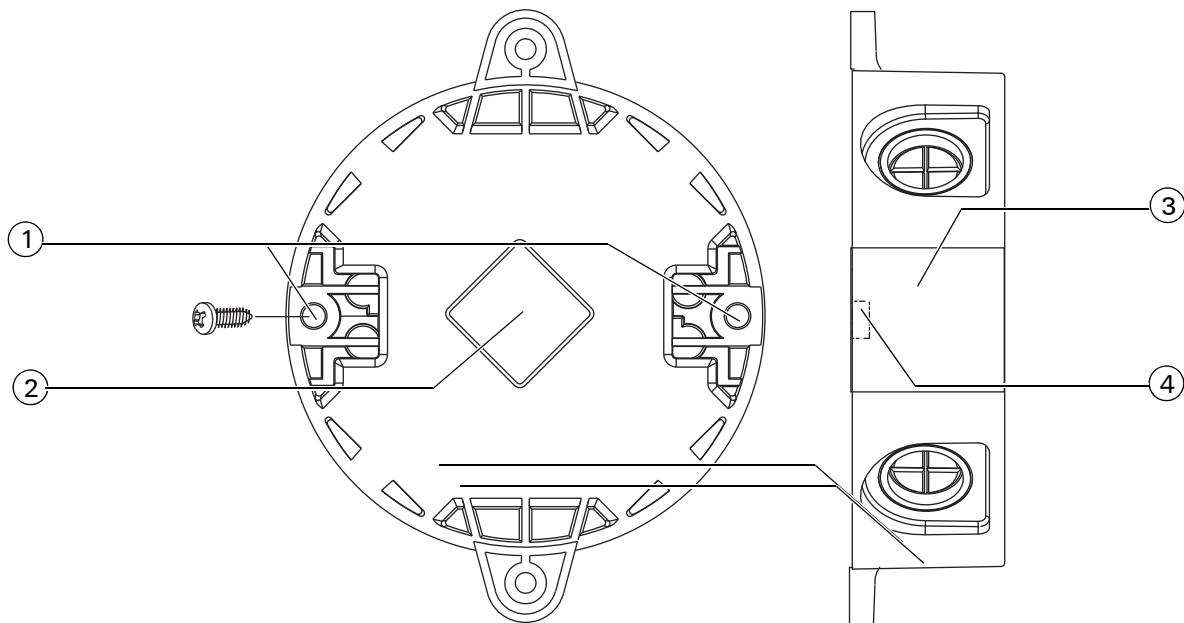

Fig. 10: 4B-DHM welding option

- 1–Screw holes
- 2–Double sided adhesive pad or tape
- 3–masking tape
- 4–Knockout

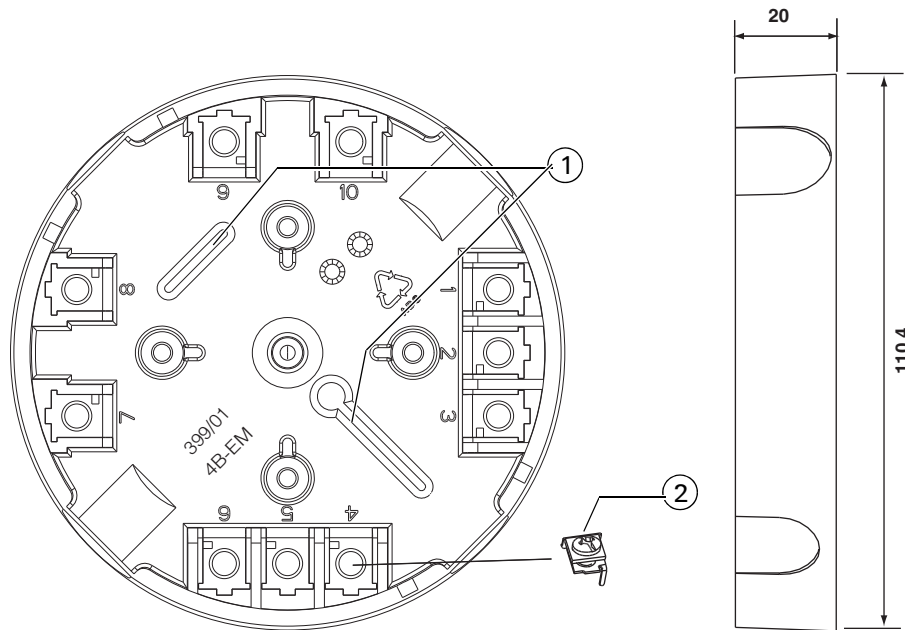

Fig. 11: 4B-EM Euro mounting box

1–Mounting slots

2–Base accessory terminal (only one factory fitted – more can be ordered)

4B-EM european mounting box

The European Mounting Box is shown in Figure 11).

This is intended for use in EC countries using 18 mm and 21 mm cable breakouts.

The housing is secured with two No. 8 x 1 inch countersunk zinc plated and passivated steel screws (or equivalent).

The surface chosen for the mounting should be flat over the area of the underside of the housing to ensure a stable fixing and strong enough to take the weight of the mounting, detector base and sensor.

4B-EM Technical specification

- Dimensions
 - Height: 21.5 mm
 - Diameter: 126 mm
 - Weight: 82 g
- Material
 - Body: Flame Retardant PC-ABS.
 - Base Accessory Terminal: Annealed spring steel
 - Base Accessory Terminal Screw: stainless steel
- Environmental
 - Operating Temperature: -25 °C to +70 °C
 - Relative Humidity: up to 95 % RH (non-condensing)

4B-6A 6" Base Adapter

Use the 4B-6A Base Adaptor for a larger area of coverage. This is useful, for example, where an older larger base is being replaced, and the marks of the old installation need to be covered.

The adapter is shown in Figure 12.

To use the adaptor

- 1 Snap off the two mounting slot covers (1).
- 2 Fix the adapter in place using screws in the slots (2). The adapter can be fitted directly to the ceiling or to a conduit junction box.
- 3 Fix the base to the adapter using screws in the slots (3).
- 4 Fix the mounting slot covers over the outer ends of the mounting slots.

4B-6A Technical specification

- Dimensions
 - Height: 16.35 mm
 - Diameter: 152 mm
 - Weight: 44 g
- Material
 - Body: Flame Retardant PC-ABS.

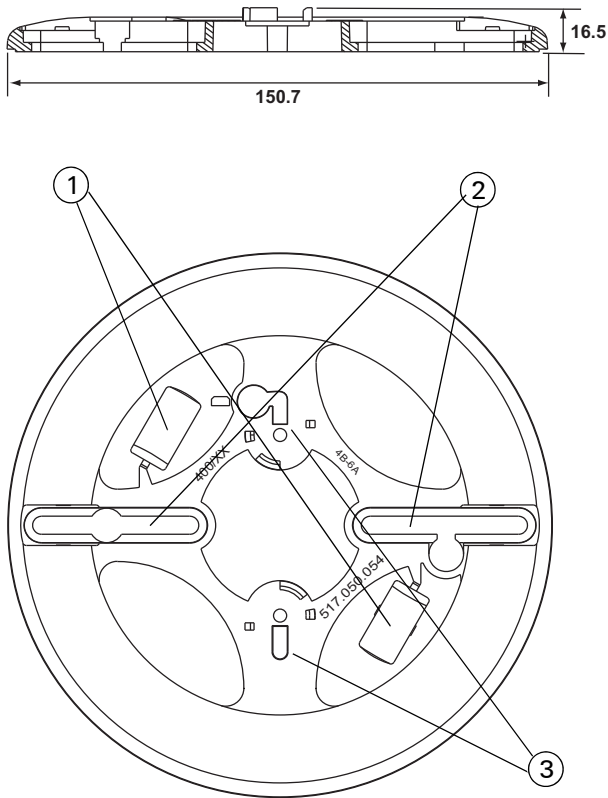

4B-CTA Ceiling tile adaptor

The Ceiling Tile Adaptor (CTA) is used to prepare a ceiling tile to be able to accept a complete base and detector assembly.

Normally the base is installed without the detector, as mounting screws must be inserted through the back plate of the base.

The CTA can save time by allowing a system to be installed and commissioned before the ceiling is installed. Once the ceiling is installed the base and detector assembly can be fitted without the need for disassembly and re-testing.

The adaptor can be ordered as a complete kit or as individual items (clamping rings and backbox).

Full details are provided in the leaflet packaged with the adaptor kit. This can also be downloaded from the Tyco EMEA website.

Fig. 12: 4B-6A 4" base 6" adaptor

1- Mounting slot covers

2- Mounting slots - adaptor to surface

3- Mounting slots - base to adaptor

Detector Removal Tool

The Detector Removal Tool is shown in Figure 13.

This tool is mainly used in reaching high locations, in conjunction with the optional extension poles.

The tool is used for the following:

- Fitting detectors from their bases, and removing them. (The Park position can also be used – see the section “Park Position” on page 3).
- Fitting detector dust covers to detectors, and removing them.

Operating instructions are shipped with the unit. These instructions can also be downloaded from the Tyco EMEA website.



Fig. 13: Detector Removal Tool

Remote Indicators

Remote indicators are used when the LED of the detector LED is not visible, for example if the detector is mounted in a roof void.

The following sections detail the two remote indicator units available.

The remote indicators appear in the simplified wiring diagrams above (for example in Figure 5 on page 4).

Full installation and specification details are packaged with the product and are also available for download from the Tyco EMEA website.

801RIL Remote Indicator

The 800RIL is shown in Figure 14. This is mounted to a single-gang electrical box.

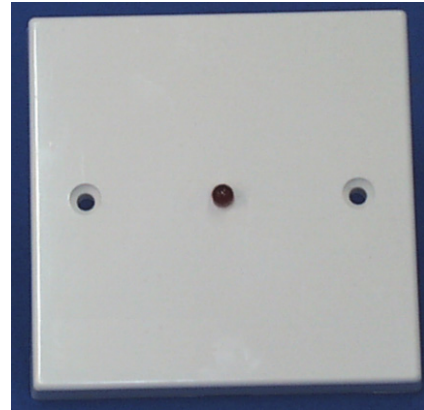

Fig. 14: 801RIL Remote indicator

801HL Remote Indicator

The 800HL Remote Indicator is shown in Figure 15.

This differs from the 801RIL in that it is more visible and can monitor up to four detectors. The indicator will illuminate when at least one of its monitored detector LEDs illuminates.

A simplified wiring diagram is shown in Figure 16.



Fig. 15: 801HL remote LED indicator

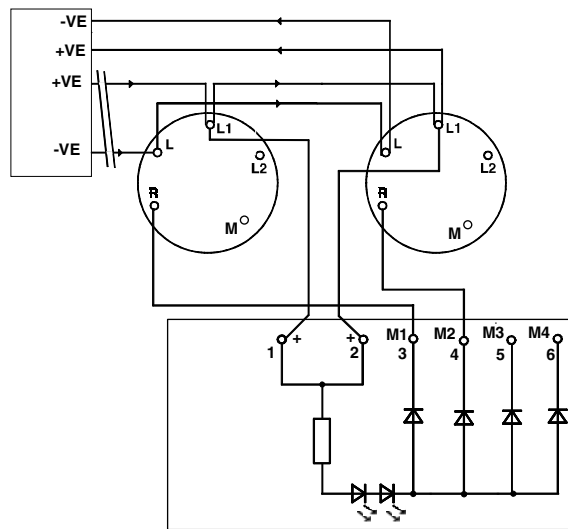

Fig. 16: 801HL remote LED indicator wiring

Detector Protective Cage

The detector protective cage is shown in Figure 17. This is designed to be fitted in areas where there is a high risk of mechanical damage to a detector. The detector cage is fitted after the detector has been commissioned. Use 4 x fixing screws suitable for the location.



Fig. 17: Detector Cage

CPR Information (4B-I)

 0786
Tyco Fire & Security GmbH, Victor von Bruns-Strasse 21, 8212 Neuhausen am Rheinfall, Switzerland 15 DoP-2015-4088
EN54-17: 2005 Short-circuit isolator for fire detection and fire alarm systems for buildings 4B-I
Essential Characteristics EN54-17: 2005 Performance under fire conditions: Pass Operational reliability: Pass Durability of operational reliability; temperature resistance: Pass Durability of operational reliability; vibration resistance: Pass Durability of operational reliability; humidity resistance: Pass Durability of operational reliability; corrosion resistance: Pass Durability of operational reliability; electrical stability: Pass
Technical information in this document (MZX-D-4B-PI)

Ordering information

Item	Order Code
4B Base	5 17.050.041
4B-C Continuity Base	5 17.050.042
4B-I Isolator Base	5 17.050.043
Address Flags (pack of 100)	5 16.800.915
Address Flag Labels Loop A (white)	5 16.800.931
Address Flag Labels Loop B (yellow)	5 16.800.932
Address Flag Labels Loop C (purple)	5 16.800.933
Address Flag Labels Loop D (green)	5 16.800.934
Address Flag Labels - Loop E (Grey)	5 16.800.935
Address Flag Labels - Loop F (Blue)	5 16.800.936
Address Flag Labels - Loop G (Orange)	5 16.800.937
Address Flag Labels - Loop H (Red)	5 16.800.938
800RT Detector Removal Tool	5 16.800.917
801RIL Remote Indicator	5 16.800.908
800HL Remote Indicator	5 16.800.909
4B-DAF DIN Address Flag (pack of 100)	5 17.050.055
4B-DHM Deckhead Mounting	5 17.050.051
4B-EM Euro Mounting Box	5 17.050.052
Ceiling Tile Adaptor Kit	5 17.050.060
Ceiling Tile Adaptor Back Box	5 17.050.056
Ceiling Tile Adaptor Bezel and Clamp	5 17.050.057
Ceiling Tile Adaptor Plate	5 17.050.058
4B-6A 6" Base Adaptor	5 17.050.054
Base Accessory Terminal (pack of 10)	5 17.050.612

Fig. 18: Order codes